

# STELTEC

V4.1-2025-08

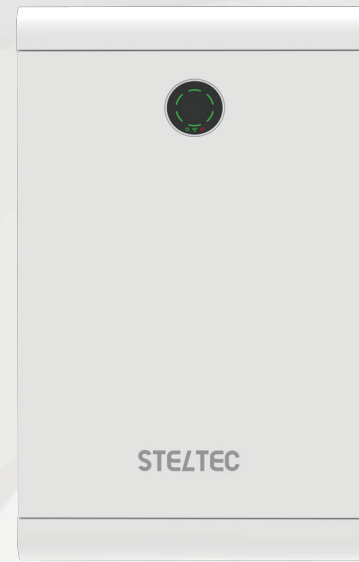

**STE-BWO-10240**

## STE-BWO-10240 Operation Manual



### CONTENTS

<b>1</b>	<b>Technical Data</b>	1-2
<b>2</b>	<b>Product Overview</b>	3
2.1	Brief Introduction	3
2.2	Interface Introduction	4
2.2.1	Switch ON/OFF	4-5
2.2.2	LED Indicator Definition	5-6
2.2.3	CAN / RS485 Port	6
2.2.4	RS232 Port	6
<b>3</b>	<b>Installation Guide</b>	7
3.1	Checking Before Installation	7
3.1.1	Checking Outer Packing Materials	7
3.1.2	Checking Deliverables	7-8
3.2	Tools	9
3.3	Installation requirements	9
3.3.1	Installation environment requirements	9
3.3.2	Installation carrier requirements	9
3.4	Installation Instructions	10
3.4.1	Dimensions	10
3.4.2	Installation Procedure	11-16
<b>4</b>	<b>Commssioning Procedure</b>	17
<b>5</b>	<b>Maintenance</b>	
5.1	Recharge Requirements During Normal Storage	18
5.2	Recharge Requirements When Over Discharged	18

# 01

## TECHNICAL DATA

### NOTE

Operating current derating according to cell voltage and battery temperature.



<b>Product Type</b>	<b>Flex-L4</b>
<b>Battery Model</b>	STE-BWO-10240
<b>Battery System Capacity</b>	10.24kWh
<b>Cell Technology</b>	Li-ion(LFP)
<b>Battery Cell Capacity</b>	200Ah
<b>Configuration</b>	1P16S
<b>Nominal Voltage</b>	51.2V
<b>Operating Voltage Range</b>	45.6~56.2V
<b>Dimension(W*D*H)</b>	480*245*815(mm)
<b>Net Weight</b>	105kg
<b>Scalability</b>	Max. 15 systems in parallel operation
<b>Installation</b>	Wall mounted or floor mounted
<b>Depth of Discharge</b>	90%
<b>Charge/Discharge Current(Recommended)</b>	100A
<b>Charge/Discharge Current(Max)</b>	200A
<b>Cooling Method</b>	Natural convection
<b>Communication Port</b>	RS232, RS485, CAN
<b>Protection Class</b>	IP65
<b>Environment</b>	Indoor or Outdoor Eaves
<b>Charging Temperature</b>	-20°C~55°C (with heating) 0°C~55°C (without heating)
<b>Discharging Temperature</b>	-20°C~55°C
<b>Humidity</b>	5%-95%
<b>Max. Operating Altitude</b>	2,500m
<b>Wi-Fi Module</b>	Built in Wi-Fi module, APP OTA function
<b>Extended Functions</b>	Thermal aerosol fire extinguishing device(standard) Heating system (optional), Wheels(optional)
<b>Certificates</b>	IEC62619 / IEC61000 / CE / UN38.3 / MSDS

## PRODUCT OVERVIEW

### 2.1 Brief Introduction

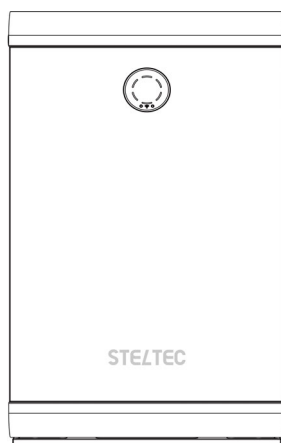

PRODUCT OVERVIEW

STE-BWO-10240 is a lithium battery with an operating voltage range between 45.6~56.16V. It is designed for residential energy storage applications and works together with a 48V battery hybrid inverter. **STE-BWO-10240 is not suitable for supporting life-sustaining medical devices.**

STE-BWO-10240 has built-in BMS (Battery Management System), which can manage and monitor cells information including voltage, current and temperature. Besides that, BMS can balance cells charging to extend cycle life. BMS has protection functions including over-discharge, over-charge, over-current and high/low temperature; the system can automatically manage charge state, discharge state and balance state.

Multiple STE-BWO-10240 can be connected in parallel to expand capacity and power, 15 pcs STE-BWO-10240 can be connected in parallel at most.

**Note:** For multiple batteries in parallel, only the Master battery SOC LED will be on to show the whole system SOC level, slave battery SOC LEDs are off, but the Normal&Alarm LED will show normally.

### 2.2 Interface Introduction

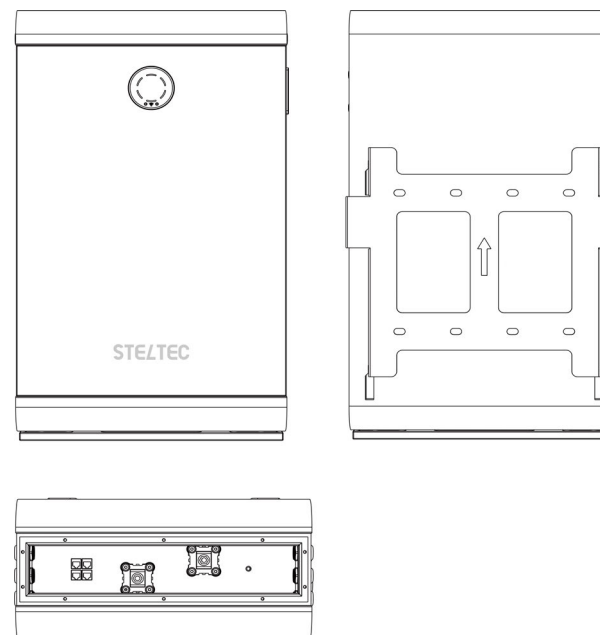

#### 2.2.1 Switch ON/OFF

##### 1. Switch ON

For single Battery Module, turn on the air switch, Long press (more than 3 seconds) Switch button, Normal LED will be lighted in the front panel then battery will operate normally. L1 to L6 shows battery SOC, L7/L8 shows battery status, L9 shows Wifi connection status.

For multiple Battery Modules in parallel, turn on the air switch of all batteries, long press (more than 3 seconds) Switch button of master battery (Which connect with inverter), normal LED will be lighted, battery system will automatically encode and assign ID to each slave battery, then battery system will operate normally.

## 2. Switch OFF

For multiple Battery Modules in parallel, turn off the air switch of all batteries, press Switch button of master battery (which connect with inverter) more than 3s, and then release the button, LED will flash in the front panel, the master battery will shut down after all slave batteries shut down (Sleep mode).

For single Battery Module, turn off the air switch, Long press (more than 3 seconds) Switch button, and then release the button, LED will flash in the front panel, the battery will shut down.

### 2.2.2 LED Indicator Definition

Note:

flash 1 - 0.25s light / 3.75s off

flash 2 - 0.5s light / 0.5s off

flash 3 - 0.5s light / 1.5s off

### LED Indicators Instructions

Status		RUN	ALM	Battery Level Indicator						Descriptions
				L6	L5	L4	L3	L2	L1	
Shut down	Sleep Mode	OFF	OFF	OFF	OFF	OFF	OFF	OFF	OFF	All OFF
	Normal	Flash 1	OFF	According to the battery level						Indicates Standby
Standby	Alarm	Flash 1	Flash 3	According to the battery level						Indicates Module Undervoltage Alarm
	Normal	Light	OFF	According to the battery level						The highest capacity indicator LED flashes (flash 2), ALM LED does not flash during overcharge alarm
Charging	Alarm	Light	Flash 3	According to the battery level						
	Full Charged Protection	Light	OFF	Light	Light	Light	Light	Light	Light	Turn to standby status when charger off
	Temperature, Overcurrent, Fault Protection	OFF	Light	OFF	OFF	OFF	OFF	OFF	OFF	Stop charging
Discharging	Normal	Flash 3	OFF	According to the battery level						
	Alarm	Flash 3	Flash 3	According to the battery level						
	Under Voltage Protection	OFF	OFF	OFF	OFF	OFF	OFF	OFF	OFF	Stop discharging
Fault	Temperature, Overcurrent, Short Circuit, Failure Protection	OFF	Light	OFF	OFF	OFF	OFF	OFF	OFF	Stop discharging
		OFF	Light	OFF	OFF	OFF	OFF	OFF	OFF	Stop charging and discharging

L9 ON: Wifi connected successfully/ L9 OFF: Wifi connection failed or power OFF.

### Charging/Discharging Battery Level Indicators Instructions

Status	Battery Level Indicator	Charging						Discharging					
		L6	L5	L4	L3	L2	L1	L6	L5	L4	L3	L2	L1
Battery Level(%)	0%~17%	OFF	OFF	OFF	OFF	OFF	Flash 2	OFF	OFF	OFF	OFF	OFF	Light
	18%~33%	OFF	OFF	OFF	OFF	Flash 2	Light	OFF	OFF	OFF	OFF	Light	Light
	34%~50%	OFF	OFF	OFF	Flash 2	Light	Light	OFF	OFF	OFF	Light	Light	Light
	51%~66%	OFF	OFF	Flash 2	Light	Light	Light	OFF	OFF	Light	Light	Light	Light
	67%~83%	OFF	Flash 2	Light	Light	Light	Light	OFF	Light	Light	Light	Light	Light
84%~100%	Flash 2	Light	Light	Light	Light	Light	Light	Light	Light	Light	Light	Light	
Running Indicator		Light						Flash 3					

### 2.2.3 CAN / RS485 Port

CAN / RS485 Communication Terminal (RJ45 port), connect to inverter, follow CAN / RS485 protocol.

PIN	Definition
Pin 1、Pin 8	RS485-B ( to PCS, reserved )
Pin 2、Pin 7	RS485-A ( to PCS, reserved )
Pin 3	NC
Pin 4	CANH ( to PCS )
Pin 5	CANL ( to PCS )
Pin 6	GND

### 2.2.4 RS232 Port

RS232 Communication Terminal (RJ45 port) follow RS232 protocol, for manufacturer or professional engineer to debug or service.

PIN	Definition
Pin 1、Pin 8	GND
Pin 2、Pin 7	RS232_TX
Pin 3、Pin 6	RS232_RX
Pin 4、Pin 5	NC

## INSTALLATION GUIDE

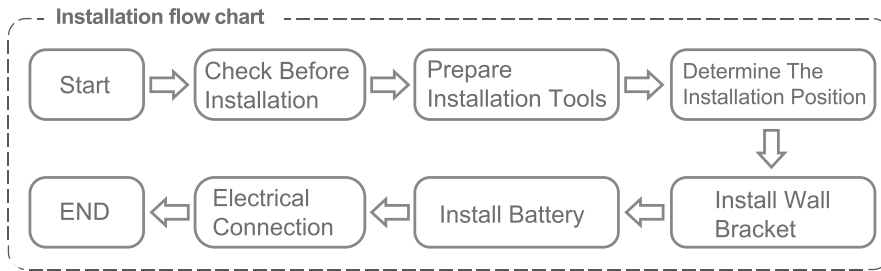
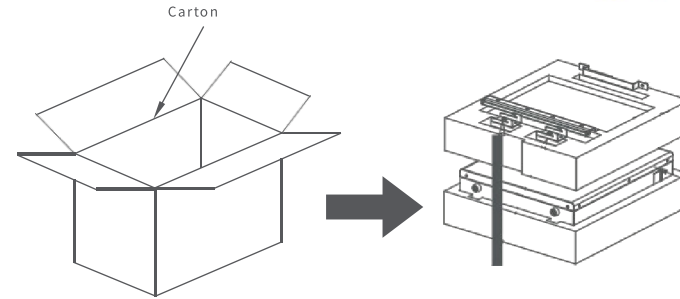

### 3.1 Checking Before Installation

#### 3.1.1 Checking Outer Packing Materials

Packing materials and components may be damaged during transportation. Therefore, check the outer packing materials before installing the battery. Checking the surface of packing materials for damage, such as holes and cracks. If any damage is found, do not unpack the battery and contact the dealer as soon as possible. You are advised to remove the packing materials within 24 hours before installing the battery.

#### 3.1.2 Checking Deliverables











After unpacking the battery, check whether deliverables are intact and complete. If any damage is found or any component is missed, contact the dealer. The below table shows the components and mechanical parts that should be delivered.

STE-BWO-10240 packing List					
No.	Part no.	Part name/size	Quantity	Photo	Used for
1	1.02.002	Battery pack	1		Battery box
2	3.01.0105	Fixed support SPCC T=2.5mm,490*430*30(L*W*H), fine sand grain	1		Wall mounting bracket
3	3.01.0133	Expansion bolt M10*30mm/3.8 grade /304 stainless steel expansion screws	8		Lock wall pendant
4	3.01.0034	Screw Cross outer hexagon three combination screws _M6*15mm_3.8 grade 304 stainless steel	1		Grounding screw
5	3.01.0137	Yellow-green two-color grounding Cable	1		Grounding Cable
6	3.01.0138	Power cord, SC70-8 at one end, SC70-10 at the other end, AV/G0# PVC cord 11627, L=1500mm, red color	1		Power cable +
7	3.01.0139	Power cord, SC70-8 at one end, SC70-10 at the other end, AV/G0#PVC cord 11627, L=1500mm, Black	1		Power cable -
8	3.01.0098	Flat gasket M8 * 20 * 1.5mm_3.8 grade 304 stainless steel	2		Accessory gasket
9	3.01.0004	Waterproof Cable Gland M25 (13-18) (Single Hole)	2		Water intrusion prevention for equipment connectors
10	3.01.0005	Waterproof Cable Gland M25(13-18) (Three Holes)	1		Water intrusion prevention for equipment connectors

STE-BWO-10240 packing List					
No.	Part no.	Part name/size	Quantity	Photo	Used for
11	3.01.0134	SC70-8_Purple Copper Tinned Terminals	2		To parallel with multiple packs
12	3.01.0064	T568B Lan cable _Line length 2000mm_ RJ45 crystal plug	1		Communication cable between master pack and inverter or for parallel of multiple packs
13	3.01.0089	RJ45 Crystal head	2		RJ45 Crystal head
14	3.01.0094	Desiccant 2g moisture-proof desiccant	2		Moisture-proof
15		Outgoing Inspection Report	1		Outgoing Inspection Report
16		Battery Networking Guide	1		Battery Networking Guide

Caster Accessory Kit Packing List					
No.	Part no.	Part name/size	Quantity	Photo	Used for
1	3.01.0034	Screw Cross outer hexagon three combination screws _M6*15mm_3.8 grade 304 stainless steel	16		Grounding screw
2	3.01.0010	Swivel wheel with brake	4		4 casters bearing capacity 800kg

## 3.2 Tools

Tools			
Installation	Knife 	Measuring tape 	Socket wrench (10/16mm) 
	Rubber mallet 	Cross Screwdriver 	Hammer drill (14mm) 
Protection	ESD gloves 	Safety goggles 	Anti-dust respirator 
	Safety shoes 		

## 3.3 Installation requirements

### 3.3.1 Installation environment requirements

- **Recommended:** Install the battery in the indoor environment.
- Place battery in secure location away from children and animals.
- Do not place the battery near any heat sources and avoid sparks.
- Do not expose the battery to moisture or liquids.
- Do not expose the battery to direct sunlight.

### 3.3.2 Installation carrier requirements

- Only mount battery on fire resistant building. Do not install batteries on flammable buildings.
- Battery is quite heavy, make sure the wall/ground can meet the load bearing requirements.

## 3.4 Installation Instructions

### 3.4.1 Dimensions

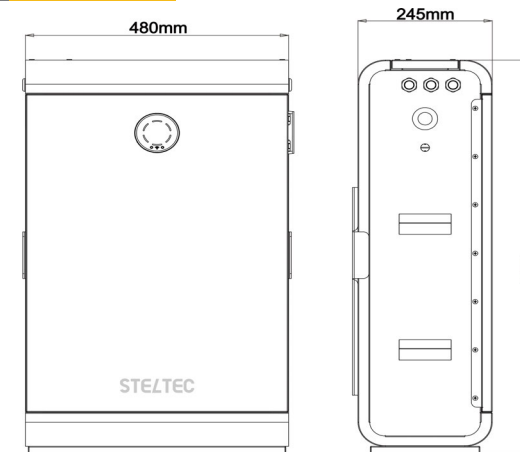

Minimum mounting distance between battery pack and equipment:

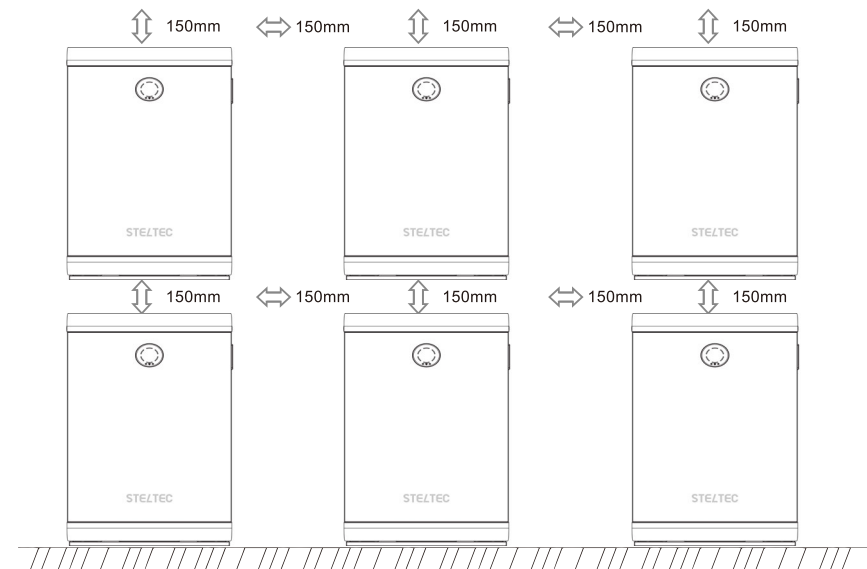

## 3.4.2 Installation Procedure

### Wall-mount installation

#### STEP 1

Drill the hole with an 14 mm drill bit as follows and fix the wall bracket to the wall.

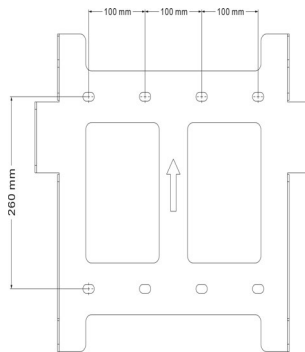

#### STEP 2

Secure the mounting bracket.

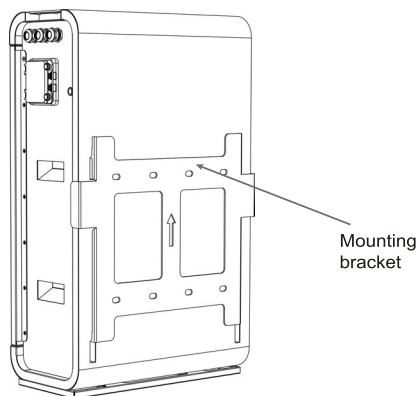

#### STEP 3

Hang the STE-BWO-10240 battery on the wall mounting bracket and secure it tightly.

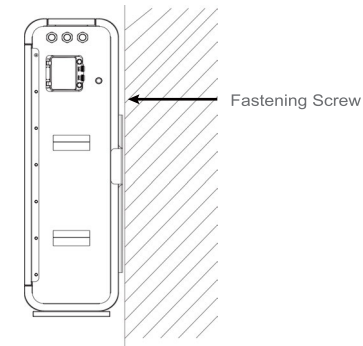

### Wheel-mount installation (alternative to Step 1- 3)

#### STEP 3

Install four lockable swivel wheels on the battery.

Place the battery on flat and firm ground, and lock the swivel wheels after positioning.

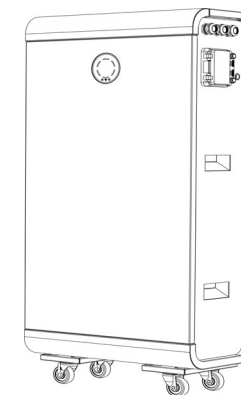

## STEP 4

Connect to ground.

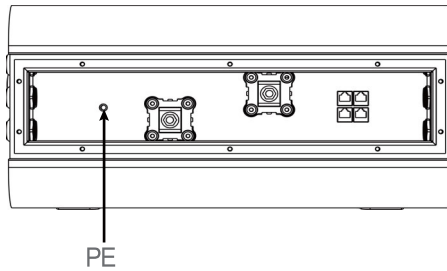

## STEP 5

Connect power cable.

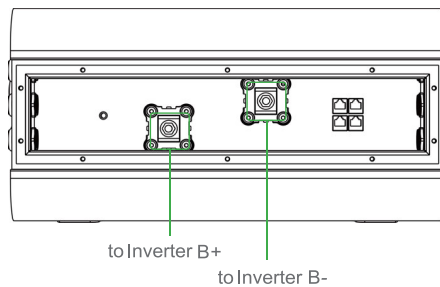

## STEP 6

Connect communication cable.

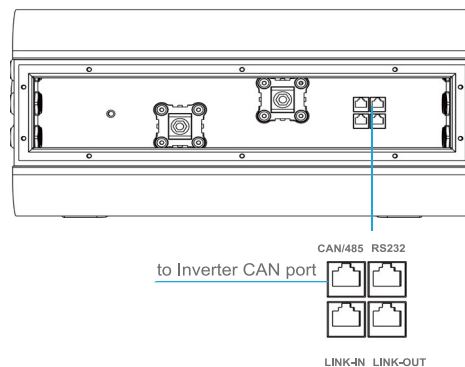



## STEP 7

1. Load power exceeding 10kW requires at least 2 units Parallel operation.
2. The maximum number of Number of parallel machines is 15. The power of the inverter selected for the battery module must be less than the maximum output power of the battery module.

Parallel operation	Load power	Connection mode
1unit	Below 10kW	7.1
2-15units	12kW or Below	7.2
2-15units	Over 12kW	7.3

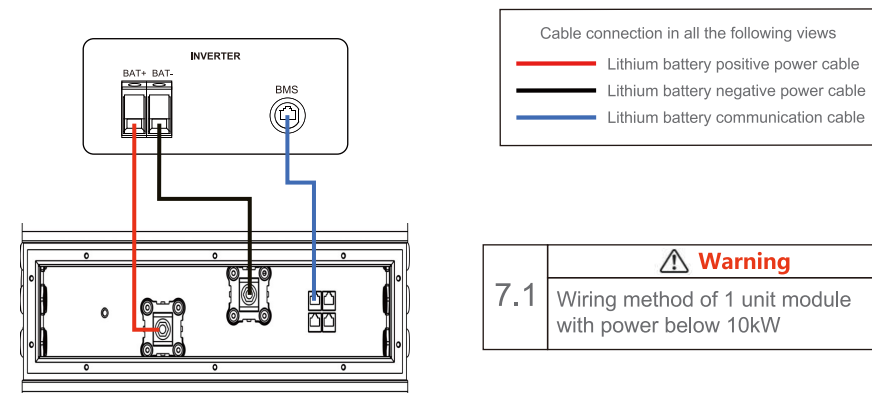
 <b>Danger</b>	Ensure power cables are installed with the correct polarity. A dangerous situation may arise if the polarities are reversed.
 <b>Danger</b>	Do not create a short circuit between the positive and negative terminals of the battery. Ensure the polarity is correct during installation.
 <b>Warning</b>	Incorrect communication cable connection will cause the battery system to operate in unexpected ways which may lead to system failure.



**7.2**  **Warning**

For 2 units -15 units is-layer module with power 12kW or below.  
 (The number of units in the middle of the diagram is omitted, the length of the two positive and negative poles connecting lines must be the same.)  
 All connection cables between the inverter and the battery must be kept at equal length to maintain proper system balance and reliable operation.

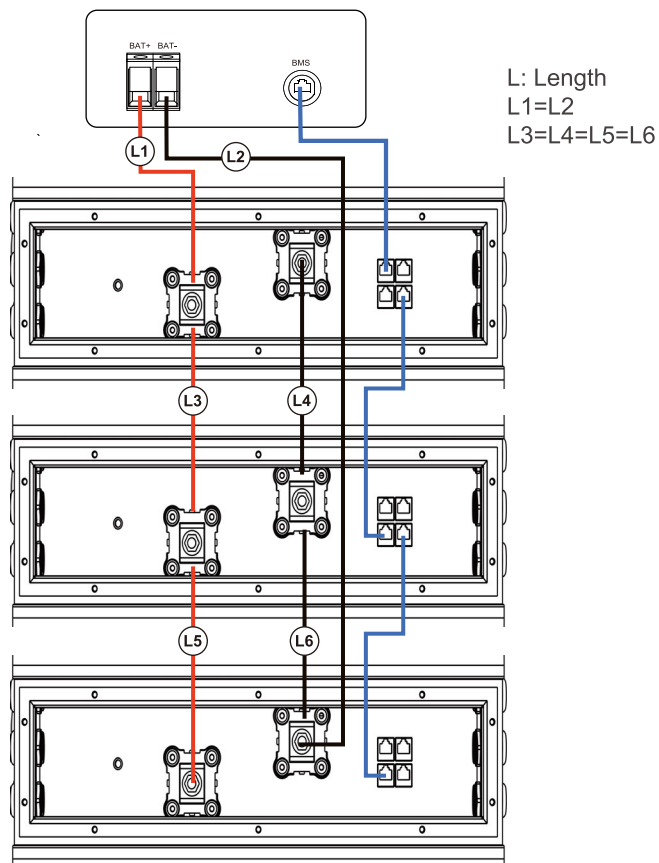

**7.3**  **Warning**

When using an inverter of above 12kW, the positive and negative ports of each battery must be connected to the combiner cabinet in the wiring method shown in the figure below.  
 For 2 units -15 units is Over 12kW.  
 (The number of units in the middle of the diagram is omitted. In order to ensure equal current flow, the length of the positive and negative poles connecting lines must be the same.)

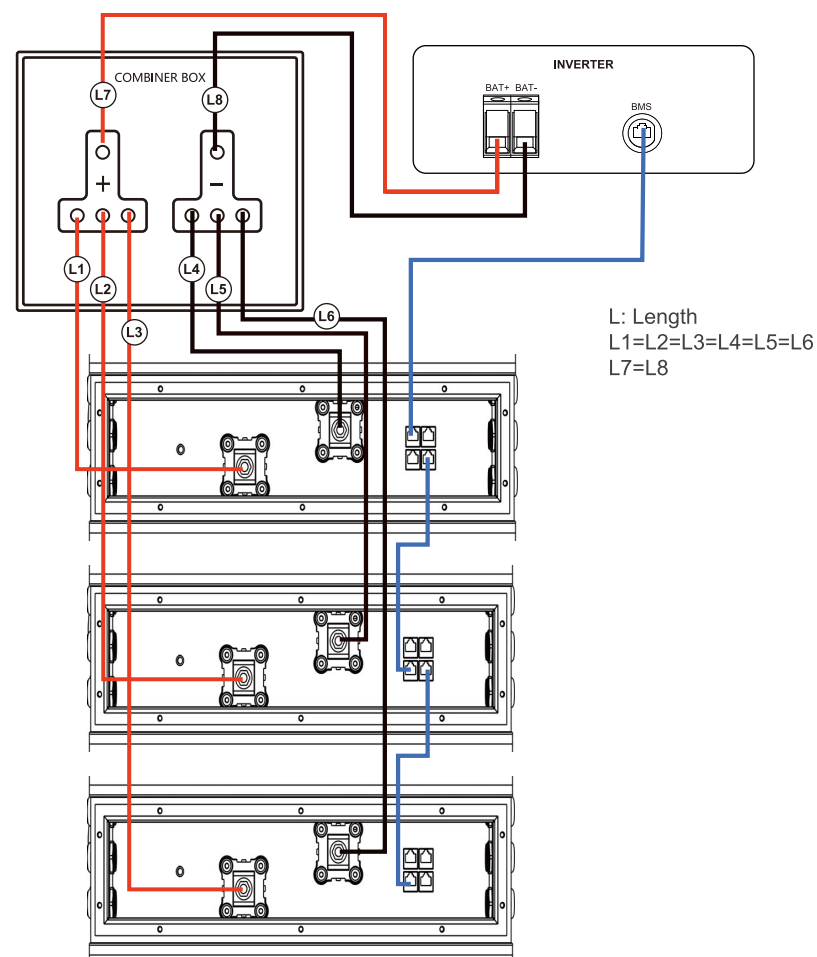

## 05

### MAINTENANCE

#### 5.1 Recharge Requirements During Normal Storage

Battery should be stored in an environment with temperature range between -10°C ~+45°C, and maintained regularly according to following table with 0.5C (100 A ) current till 50% SOC after long storage time.

##### Recharge Conditions When In Storage

Storage Environment Temperature	Relative Humidity of storage Environment	Storage Time	SOC
Below~10°C	/	prohibit	/
-10~25°C	5%-70%	≤12 months	30%≤SOC≤60%
25~35°C	5%-70%	≤6 months	30%≤SOC≤60%
35~45°C	5%-70%	≤3 months	30%≤SOC≤60%
Above 45°C	/	prohibit	/

#### 5.2 Recharge Requirements When Over Discharged

Over discharged (90% DOD) battery should be recharged according to following table, otherwise over discharged battery will be damaged.

##### Recharge conditions when battery is over discharged

Storage Environment Temperature	Storage Time	Note
-10~25°C	≤15 days	Battery Pack Disconnected from to Inverter
25~35°C	≤7 days	
-10~45°C	≤12 hours	Battery Pack connected to Inverter

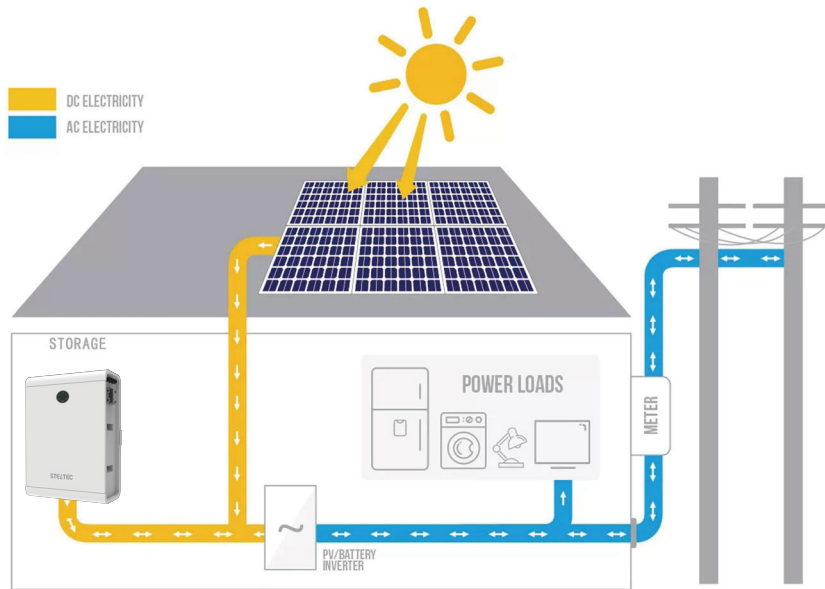

## 04

### Commissioning Procedure

After all the cable (power and communication) connections are completed, please ensure the following:

- Ensure the DC switch on the inverter is OFF
- Ensure the AC switch that is connected to the grid and EPS output (if used) of the inverter is OFF
- Ensure the DC switch is OFF

For commissioning we recommend the following steps:

- Refer to section 2.2.1 Start for turning on the battery
- Wait until the LED's on
- Wait until the inverter LED's on
- Turn the DC switch on the inverter ON
- Turn the AC switch that is connected to the grid and EPS output of the inverter ON
- **Connect the battery to Wi-Fi following the App instructions, ensure L9 LED is ON to confirm successful connection.**
- **Set-up the battery and the inverter using the App.**